

Wastewater Transfer Systems
Sistemi di trasferimento
acque reflue

Multifunctional efficient units
you can rely on
Unità multifunzionali efficienti
ed affidabili



sani-split™

sani-expert™





Taking the lead / Per essere all'avanguardia: **THETFORD**

Why choose Thetford

Thetford has over fifty years' experience globally within the black and grey water disposal sector by providing multiple solutions for both mobile and domestic applications.

Thetford's ready-to-install pump can effectively disintegrate all the waste and transfer the wastewater to the central sewage pipe or a septic tank without any demolition. With extreme reliability and low maintenance, it is multipurpose and suitable for both residential and commercial systems.

Perché scegliere Thetford

Thetford vanta oltre cinquant'anni di esperienza a livello globale nel settore del trattamento delle acque nere e grigie, fornendo molteplici soluzioni per applicazioni sia mobili che domestiche.

La gamma di unità di trasferimento delle acque reflue di **Thetford Residential** comprende le linee **Sanisplit** e **Saniexpert** che consentono di creare un bagno, una stanza di servizio o un locale lavanderia praticamente ovunque. Le pompe di macerazione o set di pompaggio con triturazione, pronte da installare, possono disgregare efficacemente tutti i reflui e trasferire le acque di scarico alla tubazione fognaria centrale o a una fossa settica senza opere di fondamento. Caratterizzati da estrema affidabilità e facilità di manutenzione, questi prodotti sono polivalenti ed adatti a impianti sia residenziali che commerciali.

Service and support

The group is recognized as the world market leader in mobile sanitary solutions, refrigerators, cooking equipment and Toilet Care products. We have grown into a formidable, global organization, yet we still successfully maintain our local perspective and presence. As an expert in macerator systems Thetford can guarantee sustainable service and support.

We have a selective and loyal network of professional distributors that can assist you in choosing just the right products and services to help make improvements and create additional comfort at home or in your business.

Servizio e assistenza

Il gruppo è riconosciuto come leader mondiale nelle soluzioni sanitarie mobili, frigoriferi, attrezzature da cucina e prodotti per la cura della toilette. Siamo cresciuti nell'ambito di una grande azienda internazionale ma continuiamo a mantenere con successo una prospettiva locale. Grazie all'esperienza nei sistemi di macerazione, Thetford può garantire servizi e assistenza sostenibili.

Abbiamo una rete selezionata ed affidabile di distributori professionali che possono aiutarvi a scegliere solo i prodotti e i servizi più adatti a migliorare il comfort a casa vostra o nella vostra azienda.

Wastewater Transfer Systems

Unità di trasferimento acque reflue

With the Thetford Residential **Sanisplit** and **Saniexpert** product lines it's possible to install a bathroom, toilet or utility room anywhere. Whether the location is at home, in a basement or attic, the choice is entirely up to you. No additional plumbing requirements are needed.

How a wastewater transfer system works

A wastewater transfer system is simple and straight forward: when a toilet is flushed, a switch and a simple electrical circuit inside the unit senses the flush and starts a very powerful macerator or grinder. The macerator or grinder then liquefies the waste and pumps it up and away to existing sewage connection.

Con la linea di prodotti **Sanisplit** e **Saniexpert** di Thetford Residential è possibile installare un bagno, una toilette o un locale lavanderia ovunque: a casa, nel seminterrato, in mansarda. La scelta sta tutta a voi e non è necessario alcun collegamento alle tubazioni fognarie!

Come funziona il sistema di trasferimento acque reflue

Il sistema di trasferimento delle acque reflue è semplice e funzionale: allo scarico della toilette, un interruttore e un sofisticato circuito elettrico all'interno dell'unità rilevano il flusso ed attivano un potente maceratore. Il maceratore disgrega i rifiuti pompando le acque reflue direttamente nella condotta di scarico principale.

Please refer to the performance and specification comparison table to find out which system matches your application best.

Fare riferimento alla tabella di confronto delle prestazioni e delle specifiche per scoprire quale sistema si adatta meglio alle proprie esigenze.

	Saniexpert	Sanisplit 1	Sanisplit 2	Sanisplit 3 Combi	Sanisplit K2	Sanisplit K3	Sanisplit Pro
Dimensions [mm] Dimensioni [mm]	421x168.5x306	270x450x175	270x450x175	270x450x175	270x450x175	270x450x175	270x450x175
Power supply [Volt AC] Alimentazione [Volt ac]	220-240	220-240	220-240	220-240	220-240	220-240	220-240
Power [Watt] Potenza	450	600	600	600	600	600	1.000
Electrical Absorption Assorbimento elettrico	2A	3A	3A	3A	3A	3A	3A
Frequency Frequenza	50Hz	50Hz	50Hz	50Hz	50Hz	50Hz	50Hz
Max. elevation head Altezza verticale max.	7 meter	11 meter	11 meter	11 meter	11 meter	11 meter	11 meter
Max. horizontal distance Distanza orizzontale max.	70 meter	90 meter	90 meter	90 meter	90 meter	90 meter	90 meter
Max. capacity Capacità max.	100 l/m	277 l/min	277 l/min	277 l/min	277 l/min	277 l/min	277 l/min
Sewage water temperature* Temperatura* dell'acqua di scarico	< 80°C	< 70°C	< 70°C	< 70°C	< 70°C	< 70°C	< 70°C
Pipe discharge size Ø [mm] Dimensione scarico tubazione Ø [mm]	23/28/32	32-40	32-40	32-40	32-40	32-40	32-40
Toilet inlet Ingresso wc	1	1	1	1	0	0	1
Other inlets Altri ingressi	3	-	1	2	1	2	2
Weight [kg] Peso [kg]	6	10	10	10	10	10	10

*For max. 10 minutes / Per max. 10 min.



sani•split™

A robust wastewater transfer system for both residential and commercial applications
Una robusta pompa di macerazione per uso domestico o commerciale

The Sanisplit family line of products has been offering complete, flexible sanitary solutions to numerous households for nearly twenty years. It offers the advantage of a macerator, a toilet inlet connection, and up to two additional inlets. It is ideal for applications requiring a compact footprint or where a wastewater transfer station is required.

La linea di prodotti Sanisplit offre da anni soluzioni complete e flessibili a numerose famiglie. Combina i vantaggi di un maceratore, una connessione per l'ingresso del wc e fino a due ingressi supplementari. È ideale per applicazioni che richiedono un ingombro ridotto o dove è necessaria una stazione di trasferimento delle acque reflue.

The two additional inlets can be connected to / I due ingressi supplementari possono essere collegati a:

- Washing machine / Lavatrice
- Laundry tub / Lavello uso lavanderia
- Shower tray / Doccia
- Bath / Vasca da bagno
- Sink / Lavandino
- Bidet / Bidet

Advantages / Vantaggi

- Patented "split" system for easy servicing / Sistema "split" coperto da brevetto per un'agevole manutenzione
- Detachable unit allowing easy access for repair without disconnecting toilet sewage discharge pipe / Distacco dell'unità motore senza necessità di scollegare il wc-tubazioni in caso di blocco o avaria meccanica
- Stainless steel blades / Lame in acciaio inox
- Clog resistant design / Design anti-intasamento
- Built in backflow prevention / Prevenzione ritorno acque di scarico integrata
- Overheat cut out protection / Protezione termica in caso di surriscaldamento
- Flexible quick installation / Installazione rapida e flessibile
- Very silent / Molto silenzioso
- Manual override button / Pratico pulsante di attivazione manuale
- Emergency discharge outlet / Scarico di emergenza

Technical highlights Specifiche Tecniche

- Max. elevation head : **11 meters**
- Toilet inlet: 1
- Other inlets: 2
- Sewage water temperature: maximum of 70°C*
- Power supply: 220-240 Volt ac
- Frequency: 50 HZ
- Pipe discharge size: ø32-40 mm
- Power: **Sanisplit Pro:** 1,000 Watt
Sanisplit: 600 Watt

* for 10 minutes

sani•split™

installation above ground
Installazione al di sopra del suolo

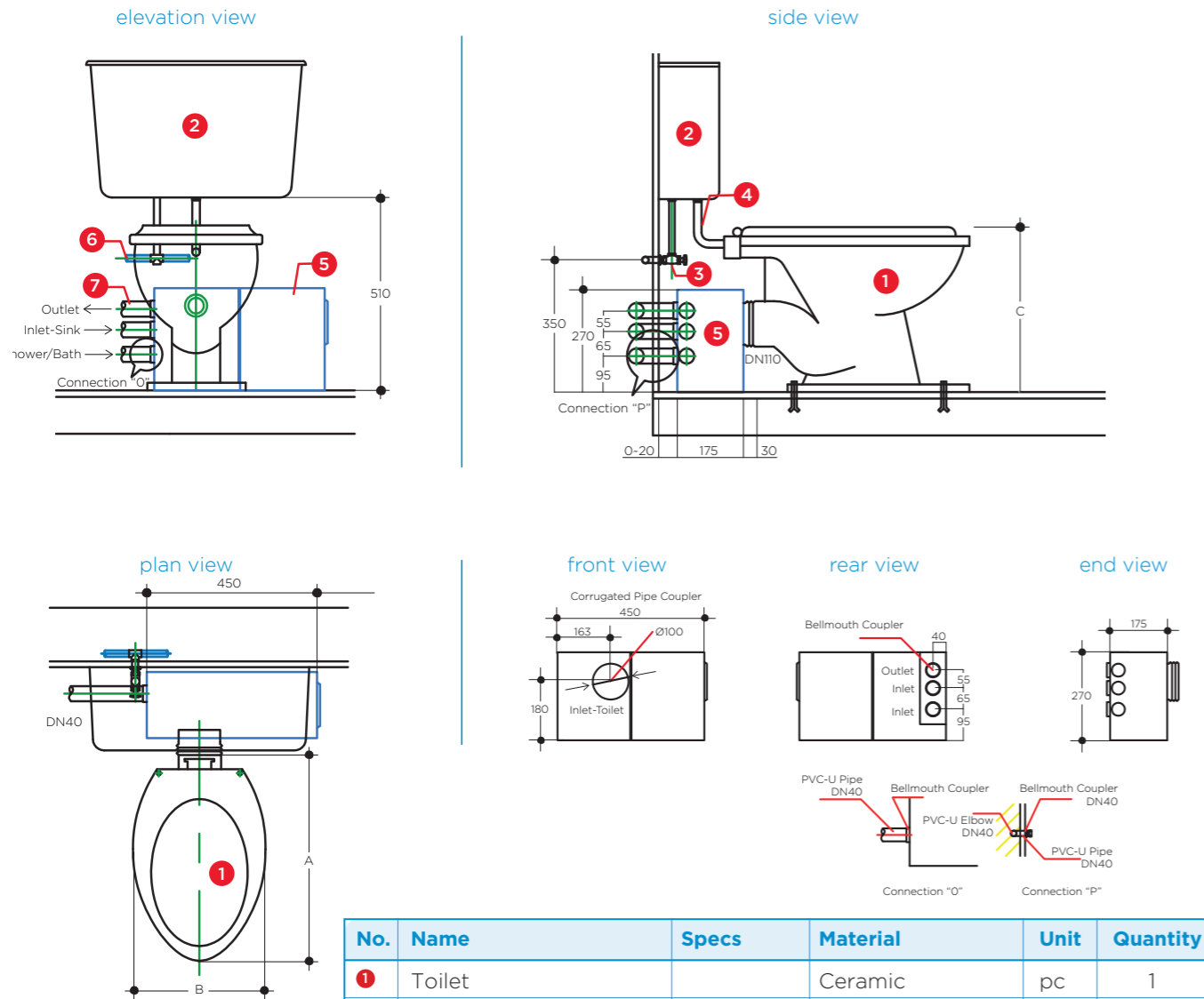

No.	Name	Specs	Material	Unit	Quantity
1	Toilet		Ceramic	pc	1
2	Tank		Ceramic	pc	1
3	Angle stop valve	DN15	Copper	pc	1
4	Flush water pipe	DN40 or DN32	PVC-U or Chrome on copper	pc	1
5	Sanisplit		Various	unit	1
6	Cold water pipe	Depend on design	Depend on design	m	
7	Pressure discharge pipe	DN40	PVC-U	m	

- Notes:**
- All drawings were based on SANISPLIT automatic wastewater transfer systems. SANISPLIT wastewater transfer system has built-in rubber water tank and macerator pump with pneumatic control system. It can operate automatically and independently. Its maximum flow rate: 8.83L/S; pump head: 11M; power: 600W.
 - Above-ground installation of the wastewater transfer system is suitable for discharging wastewater from low-tank or one-piece toilets, sinks, washing machines, bathtubs/showers.
 - It depends on the design whether the cold water pipes and pressure discharge pipe will be flush mounted or surface mounted. The pressure discharge pipe can be connected directly to the vertical or horizontal pipes of the domestic sewage system, as well as the outdoor manhole.

sani•split™

Installation below ground
Installazione al di sotto del suolo

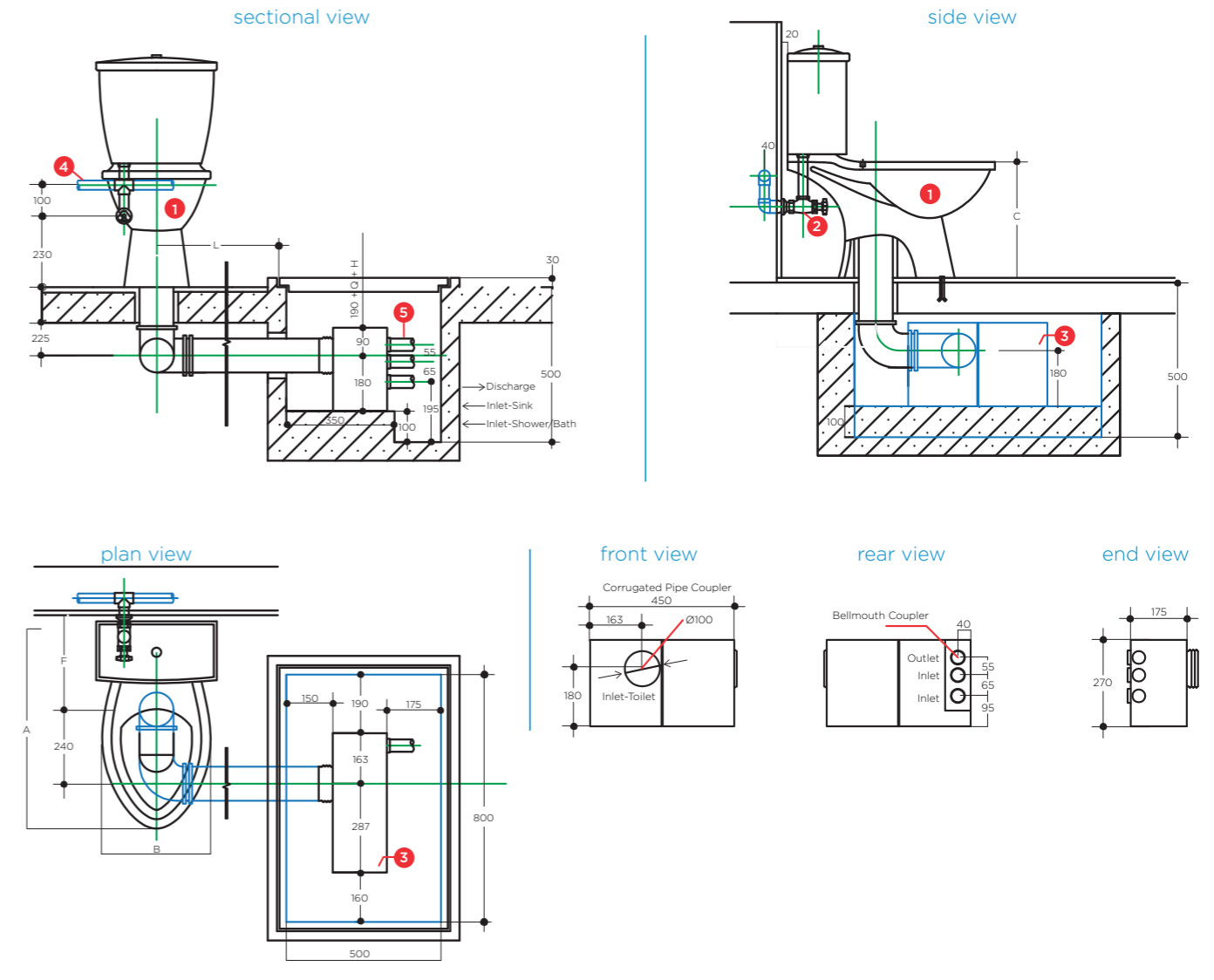

No.	Name	Specs	Material	Unit	Quantity
1	Toilet		Ceramic	pc	1
2	Angle stop valve	DN15	Chrome on copper	pc	1
3	Sanisplit		Various	unit	1
4	Cold water pipe	Depend on design	Depend on design	m	
5	Pressure discharge pipe	DN40	PVC-U	m	

- Notes:**
- All drawings were based on SANISPLIT automatic wastewater transfer systems. SANISPLIT wastewater transfer system has built-in rubber water tank and macerator pump with pneumatic control system, allowing it to operate automatically and independently. Its maximum flow rate is 5.83L/s; pump head: 11M; power: 600W.
 - Below-ground installation of the wastewater transfer system is suitable for discharging wastewater from low-tank or one-piece toilets, sinks, washing machines, and bathtubs/showers.
 - It depends on the design whether the cold water pipes and pressure discharge pipe should be flush mounted or surface mounted. The pressure discharge pipe can be connected directly to the vertical or horizontal pipes of the domestic sewage system, as well as the outdoor manholes.
 - The waterproofing pit should be designed by professional civil engineers.



sani-expert™ MOD 450

The new Thetford Residential Wastewater Transfer System with the proven Tecma reliability
 Il nuovo sistema di trasferimento acque reflue con la comprovata affidabilità dei prodotti Tecma

Technical highlights
 Specifiche Tecniche

- Max. Elevation head: 7 m
- Max. Horizontal distance: 70 m
- Toilet inlet: 1
- Other inlets: 3
- Sewage water temperature: <80°C
- Power supply: 220-240 Volt ac
- Frequency: 50 Hz
- Pipe discharge size: 23/28/32 mm
- Power: 450 W

Advantages / Vantaggi

- Extra slim and compact design / Design sottile e compatto
- Low activation pump height (10 cm) / Attivazione della pompa a soli 10 cm di altezza
- Multiple installations possibilities / Diverse possibilità di installazione
- High serviceability through the 2 covers on the top / manutenzione agevole grazie ai due pannelli superiori
- Emergency discharge outlet / Scarico di emergenza

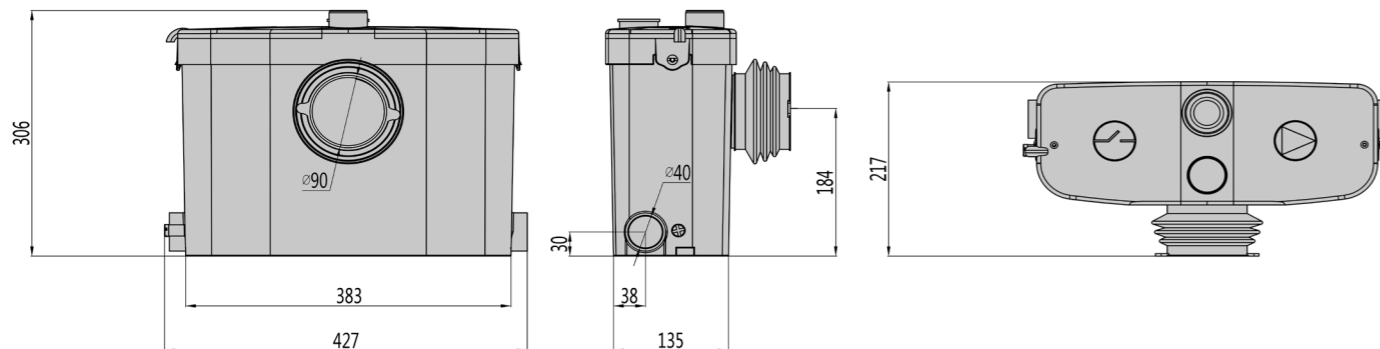

sani-expert™ MOD 450-1



- Easy to install / Facile Installazione
- Easy to maintain / Facile Manutenzione
- Easy to service / Facile Assistenza

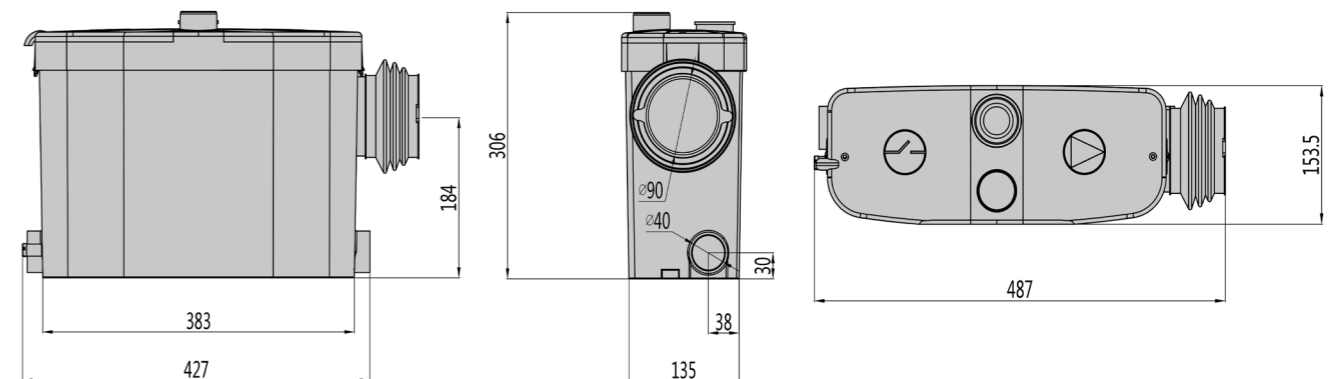

Macerating toilets

Prestige. Classic comfort

The Prestige series is designed to offer the classic comfort and feel of Thetford Residential toilets. It is offered in two different sizes and designs: The Prestige 45 and the Prestige 50

The Prestige 45 and 50 models are traditional toilets with a bowl discharge section which includes a built-in ceramic siphon to create a water trap. The solenoid and the button switch are integrated in the ceramic toilet body. These macerating toilets pump wastewater up and away through a small pipe, thus allowing the installer to create additional bathroom or washroom facilities without having to break concrete, which can be both costly and time consuming.

Prestige 45 toilet



Technical highlights

Specifiche Tecniche

- Weight: 22.5 kg
- Water usage: 0.5 - 2.7 l per flush
- Color: white
- Seat and cover: polyester
- Power supply: 230 V
- Inlet device: solenoid valve
- Control panel: integrated push button, full flush cycle
- Additional features: italian ceramic, silent flush & low water consumption

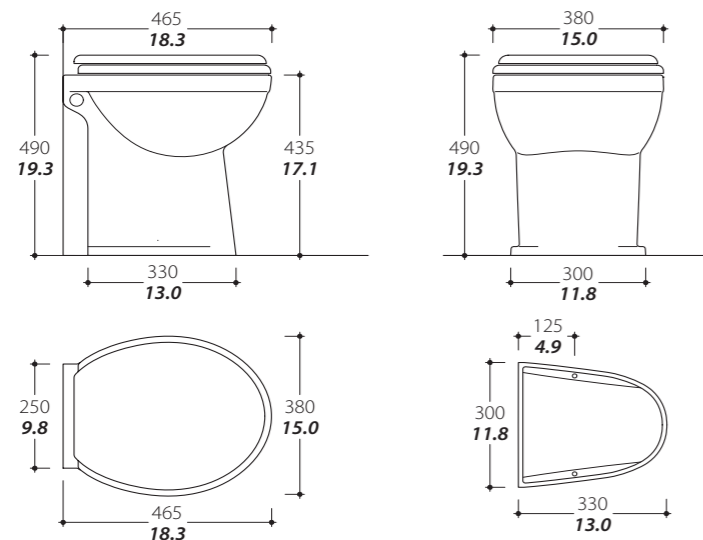

Toilette con maceratore integrato

Prestige. Il massimo del comfort

La linea Prestige è progettata per garantire il massimo comfort. E' disponibile in due differenti versioni e dimensioni: Prestige 45 e Prestige 50

Entrambi i modelli sono toilette tradizionali con maceratore integrato che consentono di scaricare le acque nere in una tubazione di piccole dimensioni e di pompare le acque di scarico in qualsiasi punto, permettendo la creazione di un servizio igienico supplementare senza interventi costosi e spese aggiuntive connesse ad operazioni di demolizione.

Prestige 50 toilet



Technical highlights

Specifiche Tecniche

- Weight: 26.8 kg
- Water usage: 0.5 - 2.7 l per flush
- Color: white
- Seat and cover: polyester
- Power supply: 230 V
- Inlet device: solenoid valve
- Control panel: integrated push button, full flush cycle
- Additional features: italian ceramic, silent flush & low water consumption

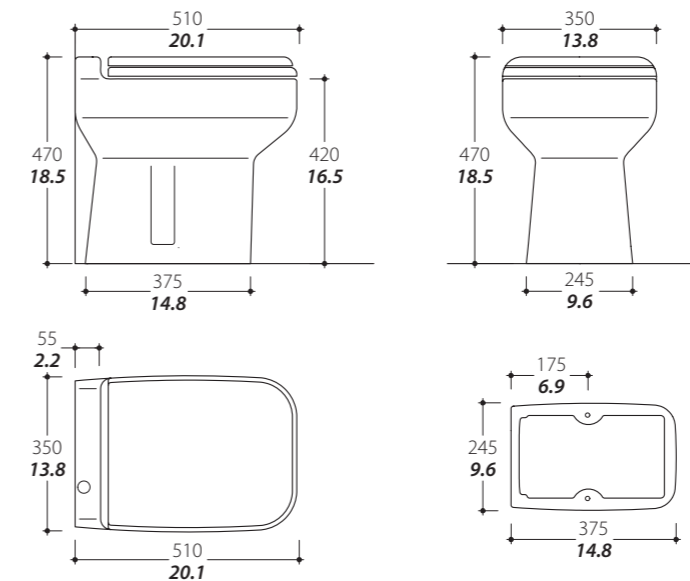



Thetford service

For additional information or to find the nearest service center visit www.thetfordresidential.com
Per maggiori informazioni o per trovare il centro assistenza più vicino visita il nostro sito
www.thetfordresidential.com



HEADQUARTER

Tecma s.r.l.
Via Flaminia
Loc. Castel delle Formiche
05030 Otricoli (TR) , Italia
T +39 744 709071
E info@tecma.eu

All rights reserved. Thetford Residential is not responsible for any printing, mechanical or other errors and reserves the right to make changes in the product specifications without prior warning.
Tutti i diritti riservati. Thetford Residential non è responsabile per qualsiasi errore di stampa, di contenuto o di altro tipo di errore e si riserva il diritto di modificare i prodotti e le specifiche senza preavviso.